



Manufacturer of shut-off and control valves

TECHNICAL DATA SHEET

**Thermodynamic condensate drain
ELEPHANT ST3232M-T DN15-25 63 bar
with filter, stainless steel, threaded**



+34 900 433 073, sales@valveelephant.com
Carrer d'Aragó, 264, 3-1, 08007 Barcelona, Spain

1. GENERAL PRODUCT INFORMATION

1.1. Product name: Thermodynamic condensate drain ELEPHANT ST3232M-T DN15-25 63 bar with filter, stainless steel, threaded.

1.2. Назначение: Конденсатоотводчик предназначен для выпуска из паровой системы конденсата, воздуха и других неконденсируемых газов, а также для задержки пара до его полной конденсации.

1.3. Operating principle: The operating principle is based on the difference in velocity between steam and condensate. When condensate passes through, due to the low velocity, the disk rises and allows the condensate to pass through. When steam enters the thermodynamic condensate trap, the velocity increases, causing the static pressure to drop and the disk drops to the seat. The steam above the disk, due to the larger contact area, keeps the disk in the closed position. As the steam condenses, the pressure above the disk drops and the disk begins to rise again, allowing the condensate to pass through.



1.5. Deciphering of the designation:

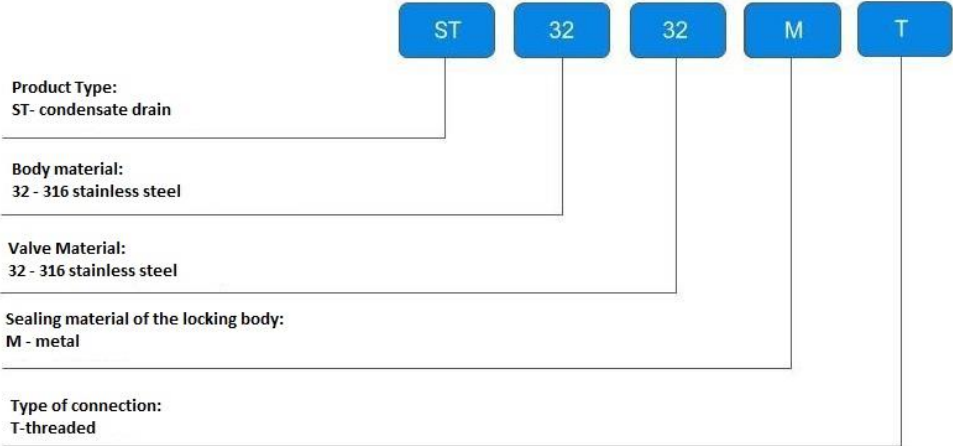

2. BASIC TECHNICAL DATA AND CHARACTERISTICS

Table 1

Nominal diameter DN, mm	15-25
Working pressure PN, bar	63
Type of condensate drain	thermodynamic
Working medium	water vapor
Maximum permissible medium temperature, °C	400
Direction of medium flow	arrow on the body
Connection to the pipeline	female thread NPT
Location on the pipeline	horizontally
Minimum pressure drop across the Minimum pressure drop across the condensate drain for normal operation, bar	0,2
Limitations	the maximum pressure downstream of the condensate drain should be no more than 80% of the pressure upstream of the condensate drain
Service life, years	10

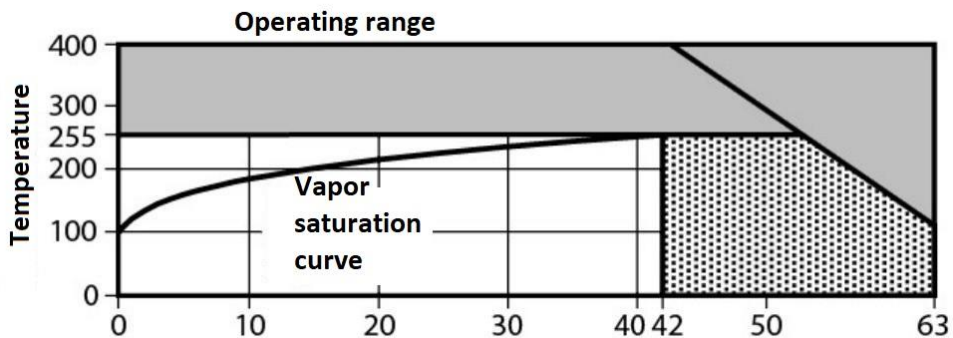

3. BASIC MATERIALS OF PARTS AND DESCRIPTION OF WORK

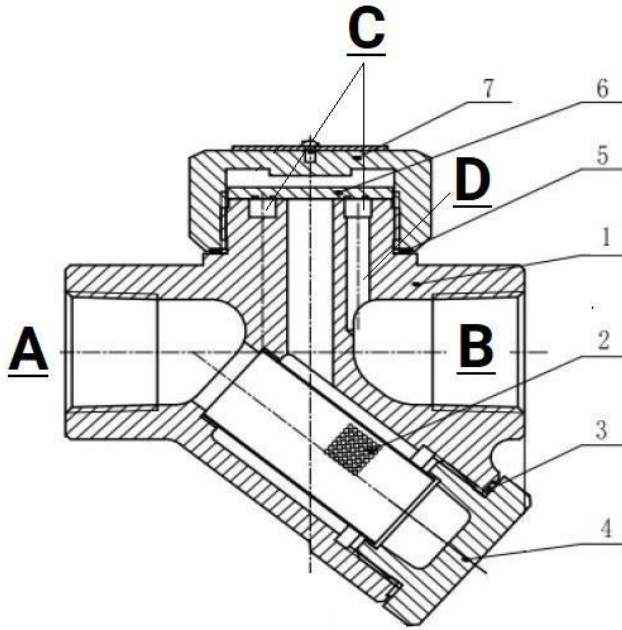

Table 2

Nº	Part name	Material
1	Body	stainless steel AISI 316
2	Filter	stainless steel AISI 316
3	Gasket	PTFE
4	Plug	stainless steel AISI 316
5	Gasket	PTFE
6	Disk	stainless steel AISI 316
7	cover	stainless steel AISI 316



The top of the body 1 has an annular groove (C) which forms the valve seat. The surfaces of the seat and disk 6 are carefully ground so that the disk fits snugly against the seat surface, providing closure between the inlet (A) and outlet (B) ports.

During start-up, air and cold condensate pass through the inlet port. The disk 6 rises and rests against the cover 7. Air and condensate flow out through the annular groove and are discharged through the outlet port (D).

As the temperature rises, some of the condensate boils as it passes through the gap between the disk and seat. Since the vapor has a lower density than water, its velocity is much higher with a corresponding drop in pressure. The static pressure under the disk drops and the disk is pressed against the seat. The disk remains pressed against the seat until the vapor under the disk condenses due to heat transfer from the cover 7, at which time the pressure above the disk drops and the disk can again be raised by the inlet pressure.

If there is no condensate, when the condensate trap is opened, a small amount of high-pressure steam will enter the chamber and the disk will be pressed against the seat very quickly.

An integrated fine filter prevents foreign matter (rust particles, sand, gauze fibers, etc.) from getting under the disc and blocking the small outlet channel D.

Thermodynamic condensate drains discharge condensate in portions. The number of actuations per minute depends on the steam pressure and the amount of condensate produced.

During normal operation, the number of actuations should not exceed 2-4 times per minute. The condensate is discharged at a temperature a few degrees below the saturation temperature of the steam at the given pressure.



4. WEIGHT AND DIMENSIONAL PARAMETERS

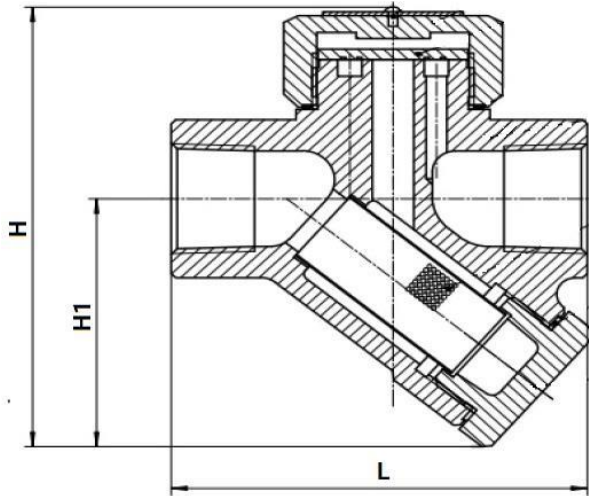

Table 3

DN	L	H	H1	Weight, kg
15	78	93	53	0,8
20	90	105	60	1,0
25	95	115	67	1,4



5. OPERATING INSTRUCTIONS

5.1. Steam traps ELEPHANT ST3232M-T do not require special maintenance. The scope and intervals of maintenance are determined by the operating organization, based on the operating conditions.

5.2. Suitable shut-off valves should be provided to ensure that the required section of the pipeline can be safely shut off for any work to be carried out on it.

5.3. When traps are used in new systems that have not been flushed, it may be necessary to inspect and clean the trap. Before servicing, isolate the section of pipe with the trap and depressurize to zero. Allow the trap to cool down. During assembly, make sure that all mating surfaces are clean.

5.4. Maintenance and repair can be carried out without removing the trap from the piping if the necessary precautions are observed. Prior to installation, disassembly and maintenance work, disconnect the trap from steam and condensate sources and depressurize the system.

5.5. When operating the trap traps, the provisions in accordance with the regulations established by the company must be followed.

6. INSTALLATION INSTRUCTIONS

6.1. The installation, operation and maintenance of condensate traps may be carried out by personnel who have studied the product design, safety rules, requirements of this TP and have skills in working with condensate traps.

6.2. Before installing a condensate trap, the piping must be cleaned of contaminants by purging. All filters must also be purged if they are installed upstream of the traps.

6.3. If there is a possibility that the system may be pressurized above the pressure limit for the condensate drain, make sure that a safety valve is in place.

6.4. If draining to the atmosphere, ensure that condensate is drained to a safe place.

6.5. The condensate drain must be installed in such a way that the direction of the medium flow coincides with the direction of the arrow on the housing.



7. TRANSPORTATION AND STORAGE CONDITIONS

7.1. Transportation and storage conditions - in the manufacturer's packaging in accordance with the conditions established at the enterprise.

7.2. Condensate traps may be transported unpacked provided that they are protected from shock loads and other mechanical effects.

7.3. Condensate drainers, which are in long-term storage, are subject to periodic inspection at least once a year. In case of violation of preservation to make preservation again. Conservation lubricant should be applied on degreased clean and dry surface of parts. Degreasing should be performed with a clean rag soaked in gasoline.

8. UTILIZATION

The product is disposed of in accordance with the procedure established at the enterprise (remelting, burial, resale).



9. WARRANTY OBLIGATIONS

9.1. Warranty period - 12 months from the date of commissioning, but not more than 18 months from the date of sale.

9.2. The warranty applies to equipment installed and used in accordance with the installation instructions and product specifications described in this data sheet.

9.3. The manufacturer guarantees compliance of the product with safety requirements, provided that the consumer complies with the rules of transport, storage, installation and operation.

9.4. The warranty covers all defects caused by the fault of the manufacturer.

9.5. The warranty does not apply:

- parts and materials of the product subject to wear and tear;
- for cases of damage caused by:
 - modifications to the original design of the product;
 - violation of general installation recommendations;
 - faults caused by improper maintenance and storage; improper operation and use of the equipment.

10. WARRANTY TERMS

10.1. Claims to the quality of the goods may be made during the warranty period.

10.2. Defective products are repaired or exchanged for new ones free of charge during the warranty period. ELEPHANT decides whether to replace or repair the product. The replaced product or its parts resulting from the repair shall become the property of 'ELEPHANT'.

10.3. Costs related to dismantling, installation and transport of the defective product during the warranty period shall not be reimbursed to the Buyer.

10.4. If the claim is unfounded, the Buyer shall pay the costs of diagnostics and expertise of the product.

10.5. Products are accepted for warranty repair (as well as for return) fully assembled.



WARRANTY CARD № _____

№	Product Name	Packs

Name and address of the trading organisation _____

Date of sale _____ Seller's signature _____

Stamp or seal of the trading organisation _____ Acceptance stamp _____

I agree with the terms and conditions of the warranty:

Buyer _____ (signature)

Warranty period - 12 months from the date of commissioning, but not more than 18 months from the date of sale.

For warranty repairs, complaints and product quality claims, please contact ELEPHANT at: Carrer d'Aragó,264,3-1,08007 Barcelona, Spain_E-mail address: sales@valveelephant.com.

When making a complaint about the quality of goods, the buyer shall present the following documents:

1. A free-form application, which shall specify:
 - name of the organisation or full name of the buyer, actual address, contact telephone numbers;
 - name and address of the organisation that carried out the installation;
 - basic parameters of the system in which the product was used;
 - a brief description of the defect.
2. Document confirming the purchase of the product (delivery note, receipt)..
3. Act of hydraulic test of the system in which the product was installed.
4. This completed warranty card.

A note on the return or exchange of goods _____

Date: « ___ » _____ 202__ r. Caption _____

