



Manufacturer of shut-off and control valves

## TECHNICAL DATA SHEET

**Strainer ELEPHANT**  
**FM1131MG-F DN50-300 16 bar**  
**cast iron, flanged**



+34 900 433 073, [sales@valveelephant.com](mailto:sales@valveelephant.com)  
Carrer d'Aragó,264,3-1,08007 Barcelona, Spain

## 1. GENERAL PRODUCT INFORMATION

1.1. Product Name: Strainer ELEPHANT FM1131MG-F DN50-300 16 bar cast iron, flanged.

1.2. Purpose. The strainer is designed for installation before regulating valves, flow meters, pumps with “wet” motor rotor and other devices with high requirements to purity of water passing through them in heating, heat supply, technical hot and cold water supply systems, for mechanical cleaning of working medium from dirt, rust, chips, etc.

1.3. The principle of operation of the mesh filter is that the working medium, passing through the filtering element (mesh), is cleaned from mechanical suspensions.



#### 1.4. Deciphering of the designation:

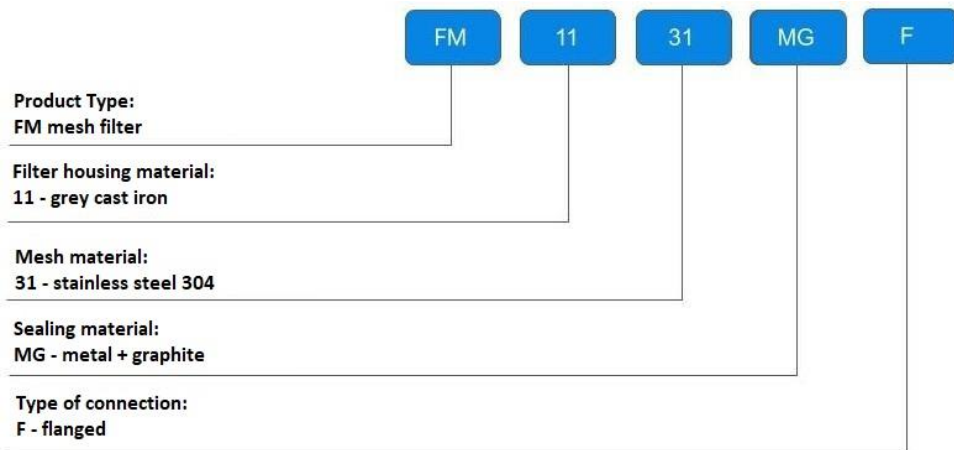

## 2. BASIC TECHNICAL DATA AND CHARACTERISTICS

Table 1

Nominal diameter DN, mm	50 - 300
Nominal pressure PN, bar	16
Working medium temperature t, °C	-10 to +300
Working medium	water, steam, oil products, antifreeze, neutral and inert gases
Working medium flow direction	filter housing arrow
Pipeline connection	flanged
Housing material	cast iron GG25
Filter screen material	stainless steel AISI 304
Areas of application	heating and water supply systems; steam plants; industrial pipelines

Table 2

DN	Throughput capacity Kv,	Grid dimensions, mm	Grid mesh size, mm
50	64,7	Ø53 x 102	0,425
65	96,0	Ø67 x 118	
80	149,0	Ø80 x 138	
100	223,0	Ø103 x 165	
125	347,0	Ø128 x 191	
150	480,0	Ø150 x 214	
200	853,0	Ø198 x 275	
250	1104,0	Ø245 x 330	
300	1450,0	Ø292 x 387	



### 3. BASIC MATERIALS

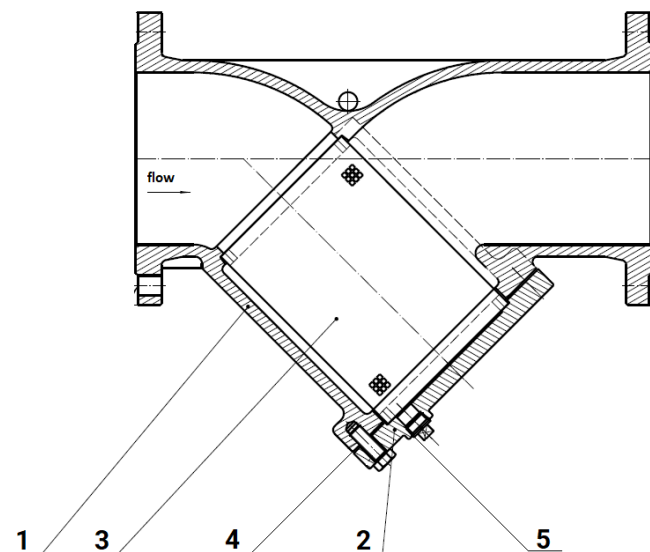

Table 3

Nº	Part name	Material
1	Housing	cast iron GG25
2	Filter cover	cast iron GG25
3	Strainer	stainless steel AISI 304
4	Seal	stainless steel AISI 316 + graphite
5	Drain plug	-



#### 4. WEIGHT AND DIMENSIONAL PARAMETERS

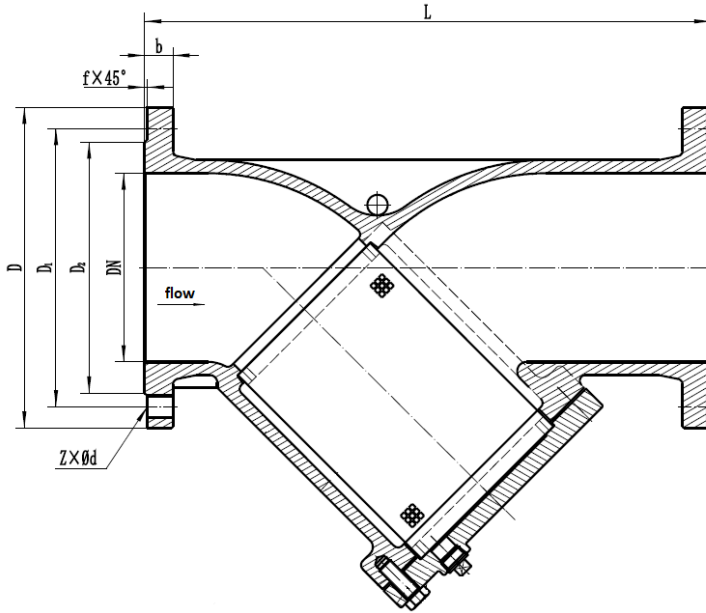

Table 4

DN	L, mm	D, mm	D1, mm	D2, mm	b - f, mm	Z - Ød, mm	Weight, kg
50	230±2	165	125	99	20 - 3	4 - Ø19	8,97
65	290±2	185	145	118	20 - 3	4 - Ø19	13,025
80	310±2	200	160	132	22 - 3	8 - Ø19	16,716
100	350±2	220	180	156	24 - 3	8 - Ø19	24,9
125	400±2	250	210	184	26 - 3	8 - Ø19	39,2
150	480±2	285	240	211	26 - 3	8 - Ø23	54,925
200	600±2	340	295	266	30 - 3	12 - Ø23	92
250	730±2	405	355	319	32 - 3	12 - Ø28	144
300	850±2	460	410	370	32 - 3	12 - Ø28	196



## 5. INSTALLATION AND OPERATING INSTRUCTIONS

5.1. Safety precautions during operation of strainers (hereinafter referred to as FS) must be observed in accordance with the procedure established at the enterprise.

5.2. Personnel who have studied the design of strainers, safety rules and requirements of the operation manual are allowed to install, operate and maintain the FS.

5.3. Before installation on the pipeline the strainers are subjected to inspection and testing, it is necessary to pay attention to the condition of internal cavities accessible for visual inspection.

5.4. FSs shall be installed in places accessible for inspection and maintenance. Before installation the pipeline shall be cleaned from dirt, scale, sand, etc.

5.6. FS can be installed on vertical and horizontal pipeline sections according to the instructions on permitted and prohibited positions in the installation (see below). On a horizontal steam pipeline it is necessary to install it with the cover sideways. The direction of flow of the working medium must coincide with the direction of the arrow on the casing.

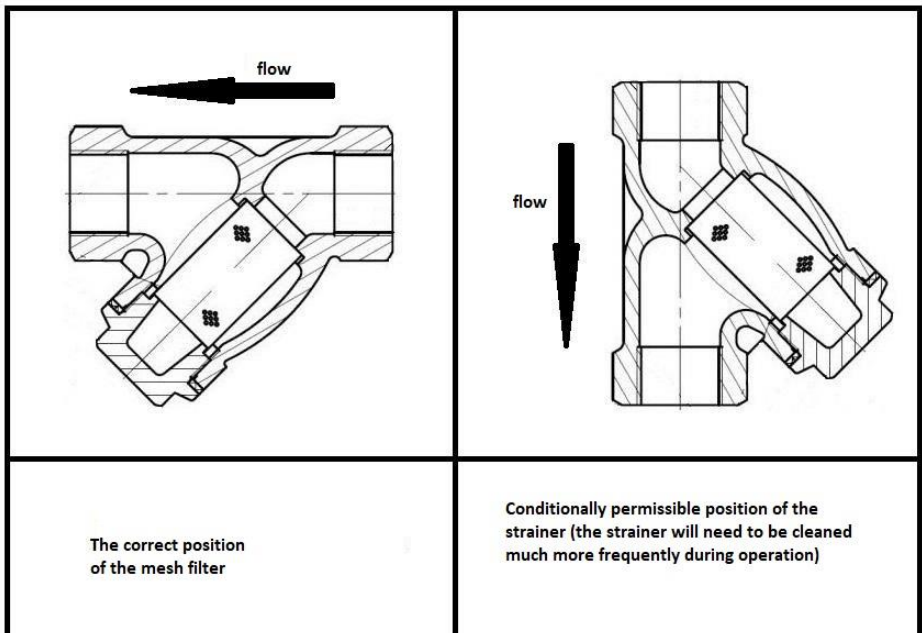

**OTHER SPATIAL ORIENTATIONS ARE UNACCEPTABLE!**



5.7. The drain plug located on the filter cover can be used to quickly clean the FS from accumulated dirt. The plug may only be opened when the system is switched off.

5.8. Depending on the quality of the working medium and requirements to the operating conditions of the protected equipment, the FS should be serviced, as a rule, at least once a year. If an FS with a mesh size smaller than standard mesh is installed, the filter shall be serviced at least twice a year.

5.9. When contamination occurs, the pressure drop across the filter mesh increases dramatically. Generally, a filter is considered too clogged when the pressure drop across the filter has increased by 30-50% of the design pressure or exceeded 1 m.h.w. = 0.1 bar = 0.01 MPa = 0.01 MPa = 10 kPa = 75 mmHg.

5.10. For complete cleaning of the filter it is necessary to remove the cover and remove the mesh. Then it is necessary to rinse the mesh under water jet to remove foreign particles, inspect the damage, replace if necessary. It is recommended to use a new gasket when installing the cover afterwards.





## **6. TRANSPORTATION AND STORAGE CONDITIONS**

6.1. Transportation and storage conditions - in the manufacturer's packaging in accordance with the procedure established at the enterprise.

6.2. It is allowed to transport the FS without packaging provided that protection from shock loads and other mechanical effects is provided.

6.3. SFs in long-term storage are subject to periodic inspection at least once a year. In case of violation of preservation, perform preservation again. Preservation lubricant shall be applied on degreased clean and dry surface of parts. Degreasing should be performed with a clean rag soaked in gasoline.

## **7. UTILIZATION**

7.1. The product is disposed of in accordance with the procedure established at the enterprise (remelting, burial, resale).

7.2. Before sending for utilization the residuals of the working medium shall be removed from the valve. Methods of removal of working medium and decontamination of valves shall be approved in accordance with the established procedure at the enterprise operating the FSs.



## 8. WARRANTY OBLIGATIONS

8.1. Warranty period - 12 months from the date of commissioning, but not more than 18 months from the date of sale.

8.2. The warranty applies to equipment installed and used in accordance with the installation instructions and product specifications described in this data sheet.

8.3. The manufacturer guarantees compliance of the product with safety requirements, provided that the consumer complies with the rules of transport, storage, installation and operation.

8.4. The warranty covers all defects caused by the fault of the manufacturer.

8.5. The warranty does not apply:

- parts and materials of the product subject to wear and tear;
- for cases of damage caused by:
  - modifications to the original design of the product;
  - violation of general installation recommendations;
  - faults caused by improper maintenance and storage; improper operation and use of the equipment.

## 9. WARRANTY TERMS

9.1. Claims to the quality of the goods may be made during the warranty period.

9.2. Defective products are repaired or exchanged for new ones free of charge during the warranty period. ELEPHANT decides whether to replace or repair the product. The replaced product or its parts resulting from the repair shall become the property of 'ELEPHANT'.

9.3. Costs related to dismantling, installation and transport of the defective product during the warranty period shall not be reimbursed to the Buyer.

9.4. If the claim is unfounded, the Buyer shall pay the costs of diagnostics and expertise of the product.

9.5. Products are accepted for warranty repair (as well as for return) fully assembled.



## WARRANTY CARD № \_\_\_\_\_

№	Product Name	Packs

Name and address of the trading organisation \_\_\_\_\_

Date of sale \_\_\_\_\_ Seller's signature \_\_\_\_\_

Stamp or seal of the trading organisation \_\_\_\_\_ Acceptance stamp \_\_\_\_\_

I agree with the terms and conditions of the warranty:

Buyer \_\_\_\_\_ (signature)

Warranty period - 12 months from the date of commissioning, but not more than 18 months from the date of sale.

For warranty repairs, complaints and product quality claims, please contact ELEPHANT at: Carrer d'Aragó,264,3-1,08007 Barcelona, Spain E-mail address: sales@valveelephant.com.

When making a complaint about the quality of goods, the buyer shall present the following documents:

1. A free-form application, which shall specify:

- name of the organisation or full name of the buyer, actual address, contact telephone numbers;
- name and address of the organisation that carried out the installation;
- basic parameters of the system in which the product was used;
- a brief description of the defect.

2. Document confirming the purchase of the product (delivery note, receipt)..

3. Act of hydraulic test of the system in which the product was installed.

4. This completed warranty card.

A note on the return or exchange of goods \_\_\_\_\_

Date: « \_\_\_\_ » \_\_\_\_\_ 202\_\_ г. Caption \_\_\_\_\_

