



Manufacturer of shut-off and control valves

TECHNICAL DATA SHEET

**Gate valve ELEPHANT
GVKR1331M-1W-Fb-S DN50-200 16 bar cast iron,
interflanged with hand wheel**



+34 900 433 073, sales@valveelephant.com
Carrer d'Aragó, 264, 3-1, 08007 Barcelona, Spain

1. GENERAL PRODUCT INFORMATION

1.1. Product name: Gate valve ELEPHANT GVKR1331M-1W-Fb-S DN50-200 16 bar cast iron, interflanged with hand wheel.

1.2. Purpose. Gate valve is designed for installation on the pipeline as a shut-off device in water supply systems and chemical industry.

1.3. The principle of operation of the gate valve is to move the gate (knife) perpendicular to the flow of the medium. At full closing of the pipeline nominal bore diameter the flow is stopped, at partial closing the flow is regulated. Tightness of the gate valve in the closed state is ensured by pressing the gate against the seal under the influence of the working medium pressure.



1.4. Deciphering of the designation:

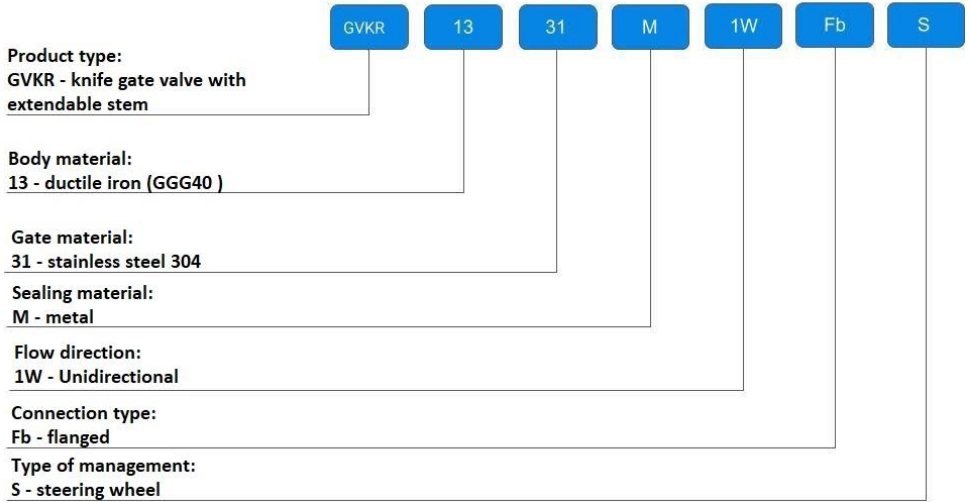

2. BASIC TECHNICAL DATA AND CHARACTERISTICS

Table 1

Nominal diameter DN, mm	50 - 200
Working pressure PN, bar	16
Working medium temperature t, °C	-20 to +250
Working medium	Wastewater, slurry, viscous, powdered and crystallized media, acids
Flow direction	single-sided
Tightness class	B
Control type	handwheel
Pipeline connection	interflanged
Body material	cast iron GGG40
Gate material	stainless steel AISI 304
Areas of application Application areas	heating and water supply systems, industrial pipelines.



3. BASIC MATERIALS

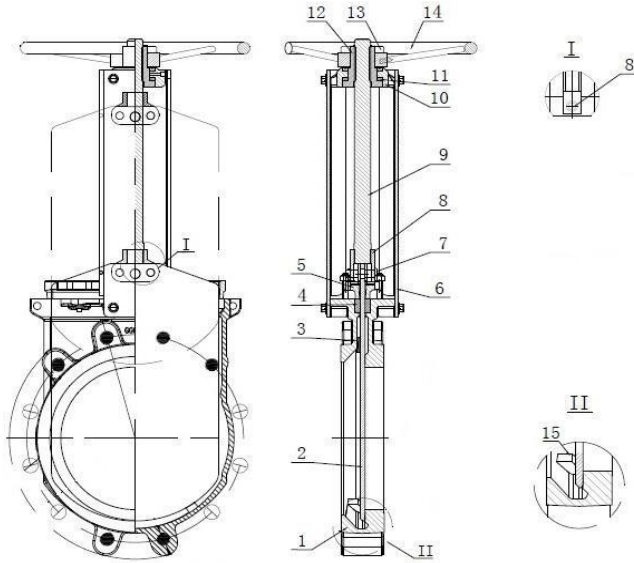

Table 2

Nº	Part Name	Material
1	Body	cast iron GGG40
2	Schieber (knife)	steel SS304
3	Guide pad	PTFE
4	Seal	PTFE
5	Gland packing	steel WCB
6	Staple	steel Q235
7	Pin	steel 45
8	Chuck	steel WCB
9	Rod	steel 2Cr13 (SS420)
10	Upper bracket	cast iron GGG40
11	Support	steel GCr15
12	Nut	brass
13	Cover	steel Q235
14	Handwheel	cast iron GGG40
15	Wedge	GGG40 cast iron



4. WEIGHT AND DIMENSIONAL PARAMETERS

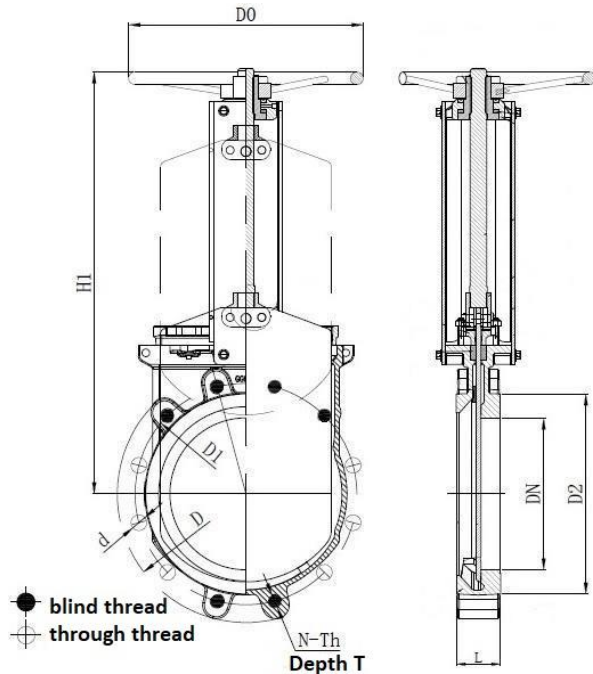

Table 3

DN	L	D	D1	D2	D0	d	T	H1	●	□	N - Th	Weight, kg
mm												
50	48	165	125	99	180	18	12	260	4	0	4 - M16	7
65	48	185	145	118	200	18	12	292	4	0	4 - M16	8
80	51	200	160	132	200	18	12	320	4	4	8 - M16	10
100	51	220	180	156	240	18	12	358	4	4	8 - M16	12
125	57	250	210	184	260	18	12	395	4	4	8 - M16	16
150	57	285	240	211	280	23	14	450	4	4	8 - M20	21
200	70	340	295	266	300	23	16	532	6	6	12 - M20	31



5. INSTALLATION AND OPERATING INSTRUCTIONS

5.1. To installation, operation and maintenance of gate valves allowed personnel who have studied the device of the gate valve, safety rules, requirements of the manual for installation, adjustment, operation and maintenance, certified for the relevant type of work.

5.2. Gate valves should be installed on pipelines for media and parameters specified in the product passport.

5.3 Before installation it is necessary to remove the plugs and make the gate valve preservation with a clean rag moistened with white spirit, gasoline or other, blow out the inner surface with clean air (in accordance with the order established at the enterprise). The pipeline should be thoroughly cleaned from dirt, sand, scale, etc..

5.4. The flanges on the pipeline shall be installed without misalignment. The pipeline shall be secured and fully unloaded by the time of installation of the gate valve.

5.5. Before starting up the system with installed gate valves immediately after installation, all gate valves shall be opened and the pipelines shall be flushed.

5.6 Tightness tests shall be carried out in accordance with the established procedure at the enterprise.

5.7. During operation it is necessary to carry out periodic inspections (routine work) in terms established by the operating organization, depending on the operating modes of the system.

5.8. During inspection check: the general condition of the gate valve, the threaded part of the spindle, which should be lubricated, the condition of bolted connections, tightness of the gasket connection and gland seal.

5.9. To ensure labor safety it is strictly forbidden to carry out works on defects elimination in the presence of excessive pressure of the working medium in the pipeline.

5.10. It is not allowed to use wrenches larger in size than it is required for fasteners.



6. TRANSPORTATION AND STORAGE CONDITIONS

6.1. Transportation and storage conditions - in accordance with the procedure established at the enterprise.

6.2. Gate valves are transported in containers in accordance with the procedure established at the enterprise and secured against possible movements with the wedge lowered to the stop. Transportation without packing is allowed, provided that there are no shock loads.

6.3. Mechanical damage and contamination of internal surfaces of gate valves during transportation is not allowed.

6.4. Gate valves should be stored in dry warehouses, protected from direct sunlight and removed at least 1 m. from heat-emitting devices, as well as not exposed to oil, gasoline.

6.5. Passage openings should be closed with plugs.

6.6. Gate valves in long-term storage are subject to periodic inspection at least once a year. In case of violation of preservation make preservation again. Apply preservation lubricant on degreased clean and dry surface of parts. Degreasing should be performed with a clean rag soaked in gasoline.

7. UTILIZATION

7.1. The product is utilized in accordance with the procedure established at the enterprise (remelting, burial, resale).

7.2. Before the valve is sent for utilization, the residues of the working medium shall be removed from the valve. The methods of removal of the working medium and decontamination of the valve must be approved in accordance with the established procedure at the enterprise operating the valve.



8. WARRANTY OBLIGATIONS

8.1. Warranty period - 12 months from the date of commissioning, but not more than 18 months from the date of sale.

8.2. The warranty applies to equipment installed and used in accordance with the installation instructions and product specifications described in this data sheet.

8.3. The manufacturer guarantees compliance of the product with safety requirements, provided that the consumer complies with the rules of transport, storage, installation and operation.

8.4. The warranty covers all defects caused by the fault of the manufacturer.

8.5. The warranty does not apply:

- parts and materials of the product subject to wear and tear;
- for cases of damage caused by:
 - modifications to the original design of the product;
 - violation of general installation recommendations;
 - faults caused by improper maintenance and storage; improper operation and use of the equipment.

9. WARRANTY TERMS

9.1. Claims to the quality of the goods may be made during the warranty period.

9.2. Defective products are repaired or exchanged for new ones free of charge during the warranty period. ELEPHANT decides whether to replace or repair the product. The replaced product or its parts resulting from the repair shall become the property of 'ELEPHANT'.

9.3. Costs related to dismantling, installation and transport of the defective product during the warranty period shall not be reimbursed to the Buyer.

9.4. If the claim is unfounded, the Buyer shall pay the costs of diagnostics and expertise of the product.

9.5. Products are accepted for warranty repair (as well as for return) fully assembled.



WARRANTY CARD № _____

№	Product Name	Packs

Name and address of the trading organisation _____

Date of sale _____ Seller's signature _____

Stamp or seal of the trading organisation _____ Acceptance stamp _____

I agree with the terms and conditions of the warranty:

Buyer _____ (signature)

Warranty period - 12 months from the date of commissioning, but not more than 18 months from the date of sale.

For warranty repairs, complaints and product quality claims, please contact ELEPHANT at: Carrer d'Aragó,264,3-1,08007 Barcelona, Spain. E-mail address: sales@valveelephant.com.

When making a complaint about the quality of goods, the buyer shall present the following documents:

1. A free-form application, which shall specify:
 - name of the organisation or full name of the buyer, actual address, contact telephone numbers;
 - name and address of the organisation that carried out the installation;
 - basic parameters of the system in which the product was used;
 - a brief description of the defect.
2. Document confirming the purchase of the product (delivery note, receipt)..
3. Act of hydraulic test of the system in which the product was installed.
4. This completed warranty card.

A note on the return or exchange of goods _____

Date: « ___ » _____ 202__yr. Caption _____

